



ECO-VALVES

Ecological Draining Solutions

Floating Roof

Automatic Shutoff Draining Valve

Type: TOR

Environmental Safety Unit





Floating Roof - Automatic Shutoff Draining Valve * Patent Pending

Environmental Safety Unit

The TOR model is a normally open specific gravity sensitive valve, which closes upon sensing the petroleum product. It is commonly used as a safety requirement for the draining of rainwater from floating roofs of petroleum product storage tanks. In the event of storage product ingress into the drain tubing or roof, the TOR Valve will sense the presence of the product and will immediately close, preventing product loss, pollution and spillage.

The TOR model is a normally open valve installed on the outlet flange of the roof manual drain valve of the storage tank. It presents a constant open passage ready to drain any water that accumulates on the storage tank roof and ready to immediately close in the event of product ingress into the drain system.

When the TOR closes, the factory fitted magnetic proximity switch can immediately send a feedback signal to a remote position monitoring system, alerting the relevant authority and enabling speedy corrective action.

It uses a simple reliable principle with a straightforward and compact construction. The TOR is designed to require minimum maintenance, and to last the lifetime of the tank.

Each valve is assembled and fully tested in the ISO 9001 certified manufacturing plant. Introduced to the industry years ago, the TOR is a time proven product in use in over 20 countries worldwide and backed by the Global Service Network of ECO-VALVES.



Features and Benefits

- High accuracy
- Rapid reaction
- Very low maintenance
- No external power supply needed
- Integral Strainer
- Open / Closed Position Indicator / Alarm
- Integral Automatic Air Vent / Air Eliminator
- Limit Switch: Atex / IECEx/Nema Certified, Approved for hazardous areas

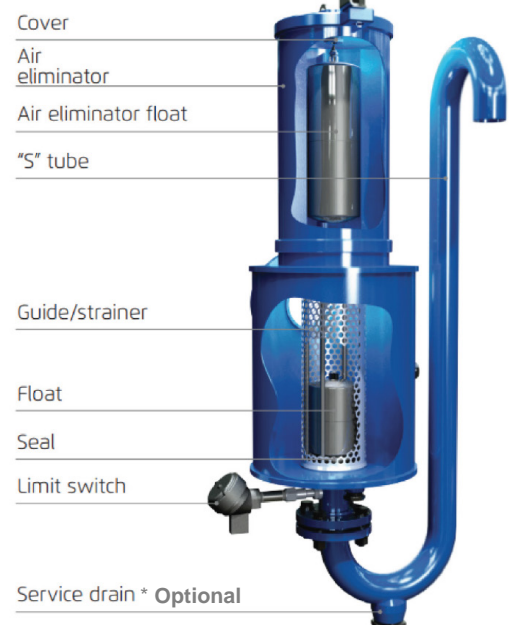



Principle of Operation

Normal Operation (Standby)

The TOR valve is normally open and connected to the drain pipe outlet valve [1] of the storage tank floating roof. When conditions are dry the valve remains open and in a standby mode. Remaining open to drain any water that enters into the drain pipe and to immediately close in the event of product ingress to the drainage system of the storage tank.

Normal Operation (Draining)

During rainfall water drains via the Normally Open TOR valve, the float [2] floats in the water and the open valve allows the flow of water from the roof to the drain [3] in a regular fashion. As water enters the TOR any air which may have accumulated inside the valve or which is drawn down during high flows, will be immediately expelled by the air eliminator [4]. Ensuring continued safe and reliable functioning of the drain. During the draining process the integral strainer helps to keep the valve seat free of debris and dirt typical of floating roofs that otherwise might compromise the sealing integrity of the valve.

Reaction to Drainage System Failure

In the event of product ingress to the drainage system, for example a rupture in the drain pipe [5], product enters into the TOR valve and the float [2] will immediately sink in the lighter fluid thereby sealing the TOR valve and preventing product spillage. The limit switch [6] will detect the valves closed position which can be immediately conveyed to the relevant service unit enabling speedy corrective action.

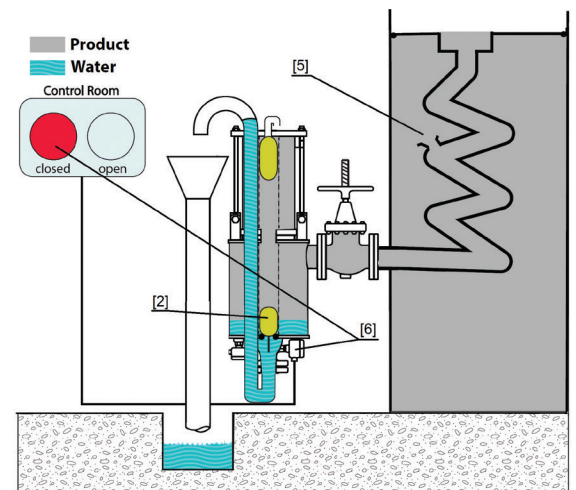
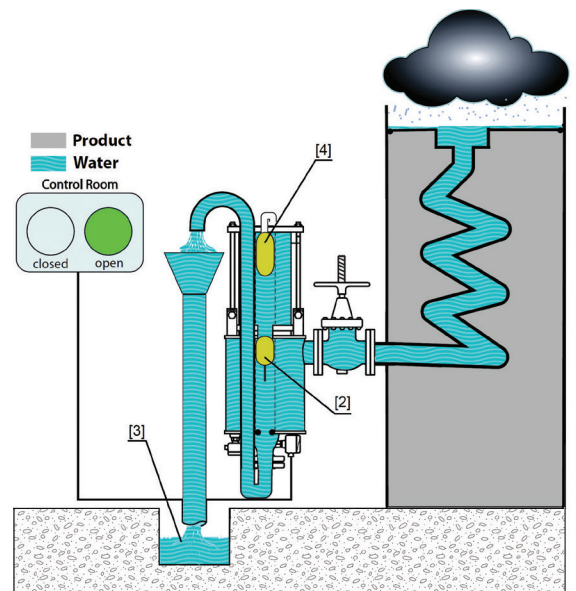
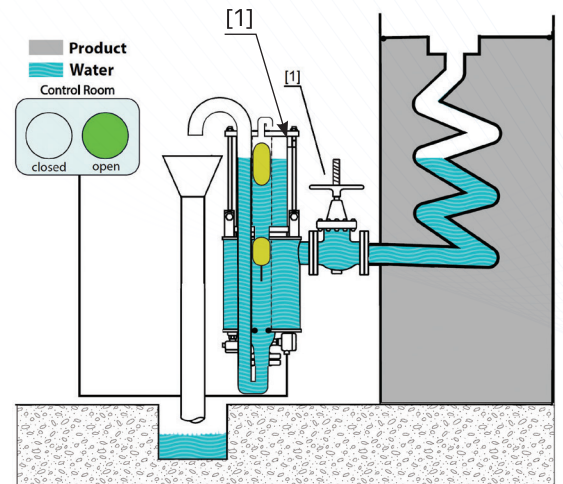



Typical Installation

Parts List

1. Main Drain Valve
2. TOR Valve
3. Emergency By-Pass Valve
4. Equalizing "S" Pipe
5. Limit Switch
6. Roof Drain Pipe
7. Storage Tank

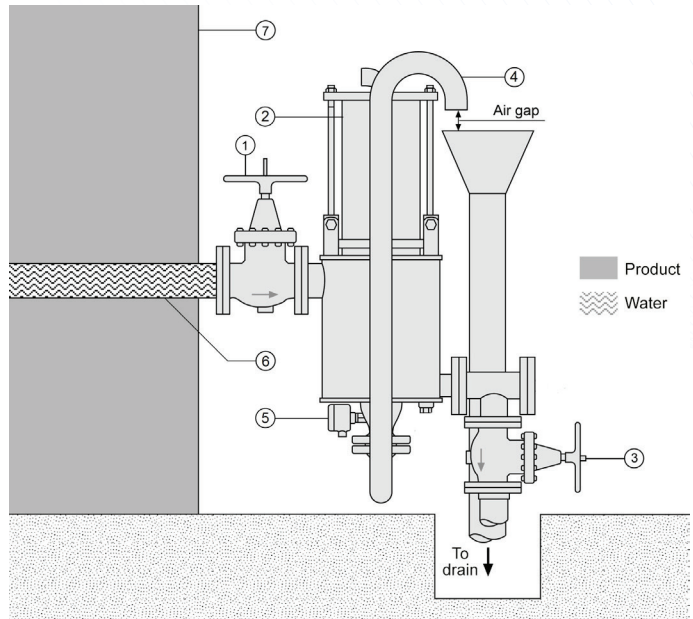

The TOR valve is typically installed as a safety requirement integral to the draining system of floating roof storage tanks, preventing accidental spillage as the result of a breach in the roof drain system. The TOR should be connected to the outlet valve of a draining pipe leading from the storage tank roof to the drainage system. For sizing first calculate the maximum or critical flow needed to keep the roof drained, taking into consideration the roof area and the critical rainfall, next refer to the flow chart on page 4. The Y axis or Inlet Head can be considered roughly equal to the anticipated roof height. The flow will be at its maximum when the roof is at its highest, and at its minimum when the roof is at its lowest. Where one TOR valve does not meet the requirements of the calculated maximum flow rate, additional TOR valves can be installed in a manifold arrangement.

The TOR valve is typically installed as a safety requirement integral to the draining system of floating roof storage tanks, preventing accidental spillage as the result of a breach in the roof drain system. The TOR should be connected to the outlet valve of a draining pipe leading from the storage tank roof to the drainage system. For sizing first calculate the maximum or critical flow needed to keep the roof drained, taking into consideration the roof area and the critical rainfall, next refer to the flow chart on page 4. The Y axis or Inlet Head can be considered roughly equal to the anticipated roof height. The flow will be at its maximum when the roof is at its highest, and at its minimum when the roof is at its lowest. Where one TOR valve does not meet the requirements of the calculated maximum flow rate, additional TOR valves can be installed in a manifold arrangement.

P&ID

- | | |
|-------------------------------------|--------------------------|
| 1. Inlet from tank roof | 7. "S" pipe |
| 2. Specific gravity sensitive float | 8. Drain flute / air gap |
| 3. Air eliminator float | 9. Plug |
| 4. Seal | 10. Drain |
| 5. Bypass valve | 11. Limit switch |
| 6. Vent | 12. Float guide/strainer |

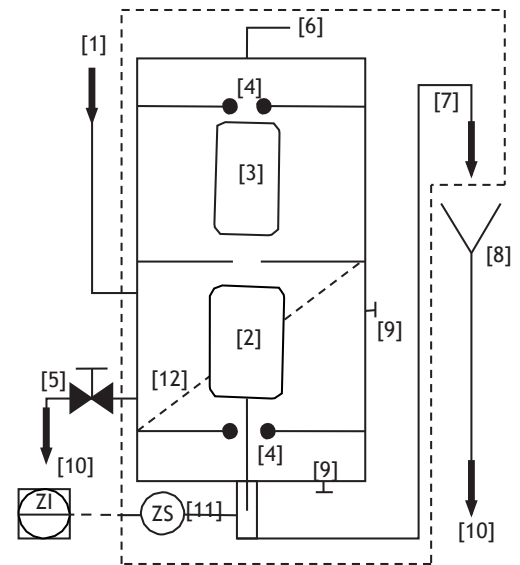

Engineering Specifications

The Automatic Draining Valve shall be made of a fusion bonded epoxy coated coated carbon steel body and will include an integral stainless steel Strainer.

The valve shall include an integrated air relief valve for the elimination of trapped air.

The Valve shall include a factory fitted limit switch properly certified for hazardous sites classifications.

All fittings, bolting and all metallic internal parts shall be made of stainless steel. No additional parts shall be required for resetting.

Removing the valve cover for inspection or maintenance shall be in line and shall not require removal of the valve from the pipeline.

The Automatic Drain Valve shall be assembled and hydraulically tested by a factory certified to ISO 9001-2015.



Technical Specifications

Part	Material
Valve Body and Cover	Epoxy Coated Carbon Steel
Internal Parts	Stainless Steel
Seals	FKM
Coating	Fusion Bonded Epoxy RAL 5017
Plugs	Stainless Steel
Bolts	Stainless Steel
Inlet Connection*	4" ANSI #150 RF B16.5
Drain Outlet Pipe	2"
Limit Switch	Stainless steel – Certified for Hazardous locations
Working Pressure	2.5 bar - 36 psi
Approx Weight	87 kg / 192 lb

*Other connections available – contact ECO-VALVES

Dimensions

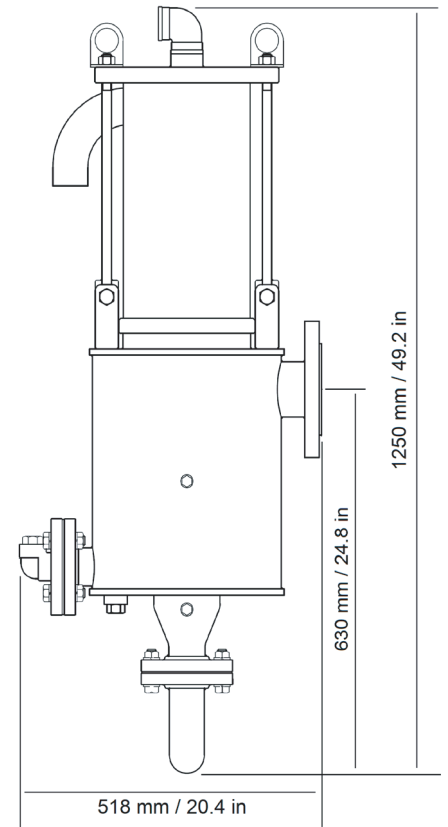

Flow Chart

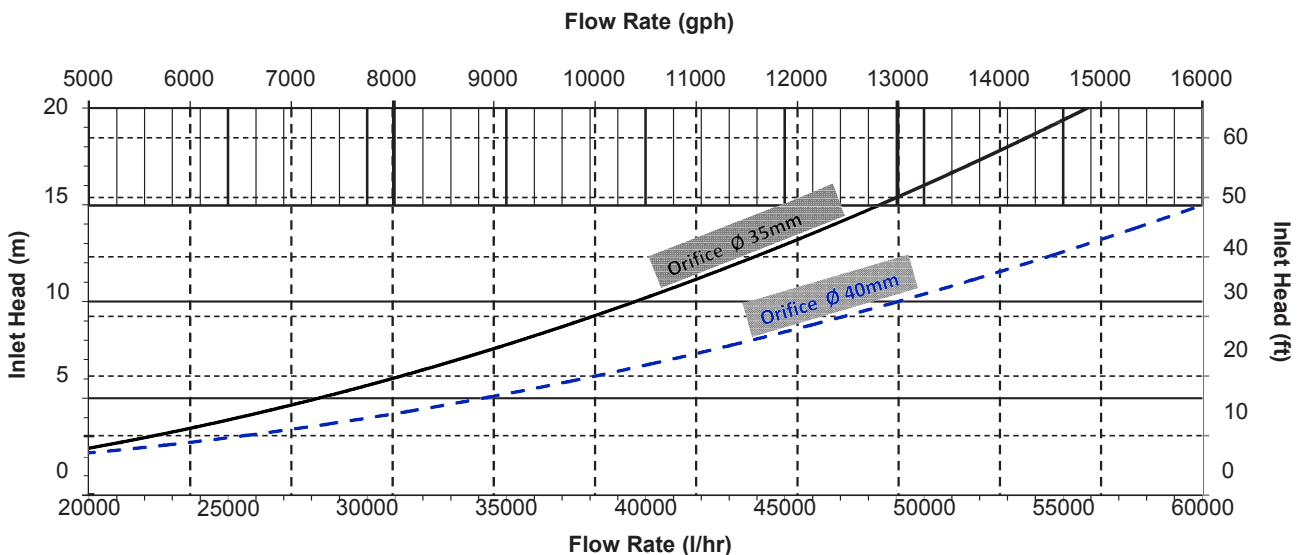

Product

Water



ECO-VALVES
Ecological Draining Solutions